

SHERCO

RACE PREPARATION 2 STROKE RANGE



ATTENTION!

Before modifying the vehicle to the race version, please insist on obtaining a signed workshop order from your customer in which you inform the customer's own risk and that it nullifies the vehicle's approval for use on public roads.

Please don't throw the removed parts and give them to the customer

Remark :

Please make sure that no third person has access to this manual



EXHAUST

Remove catalytic exhaust pipe (7106 → 125/300) (5911 → 125) and AIS valve (H377) Install racing exhaust pipe .

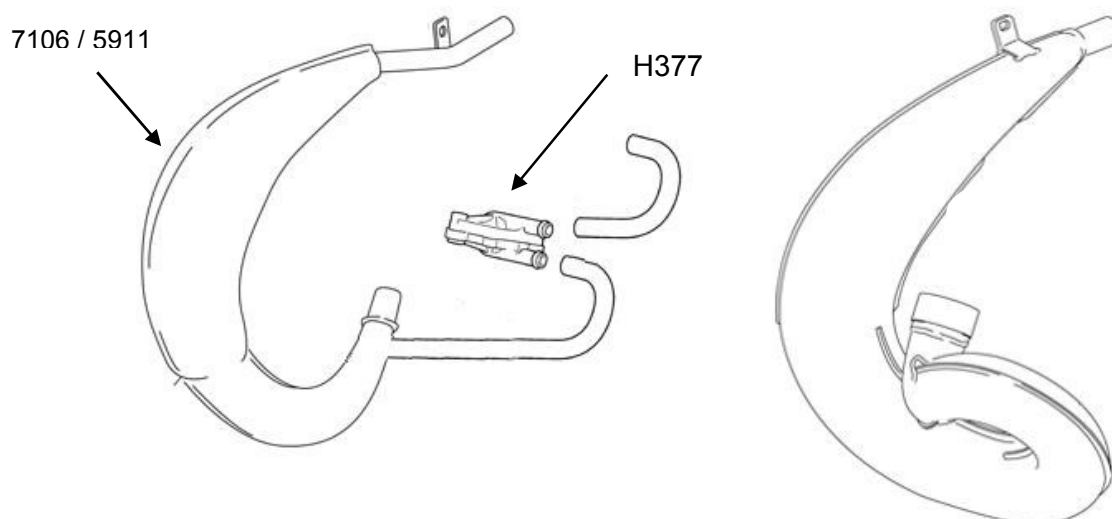

INTAKE

Remove intake restriction (6856) and place filter basket (3044)

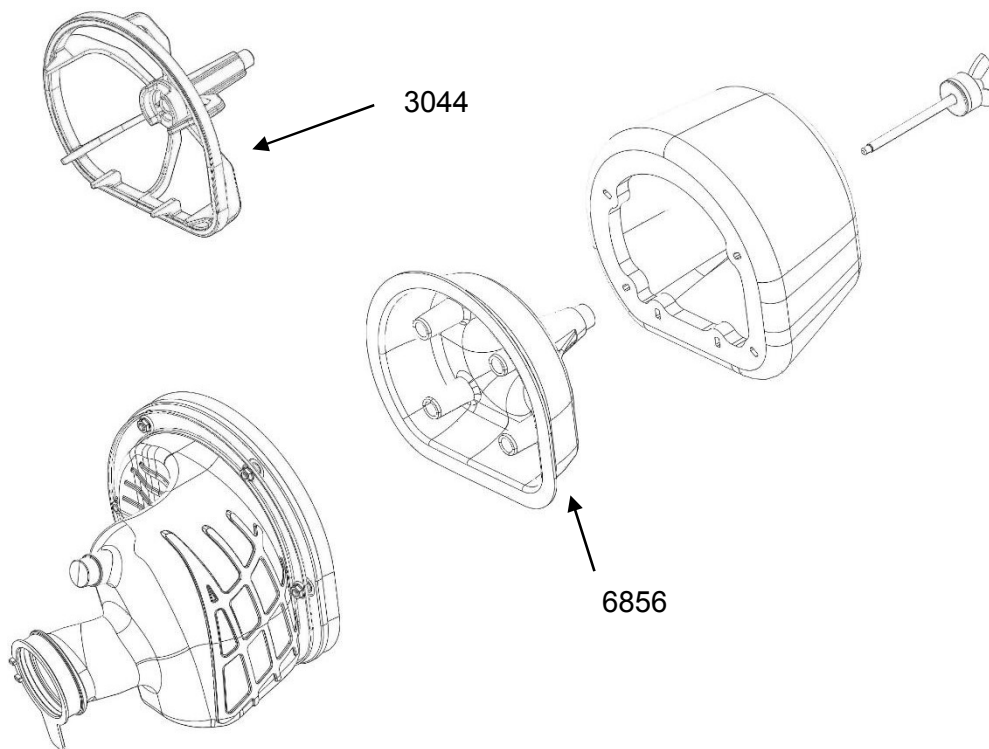

Connecting the bike to the diagnostic tool and making sure that there is the last updated mapping is installed. All mappings are available on the sherconetwork:
INFORMATION → TECHNICAL INFORMATION → INJECTION MAP

Date	Description	File	View
26/02/2018		302T8C04 300 8E-R 2018 (with ooil 8308).mot	DOWNLOAD
26/02/2018		262T8C04 260 8E-R 2018 (with ooil 8308).mot	DOWNLOAD
16/01/2018		302T8C03 300 8E-R.mot	DOWNLOAD
16/01/2018		262T8C03 260 8E-R.mot	DOWNLOAD
12/10/2018		464EU801 460 8EF 2017 STANDARD.mot	DOWNLOAD
12/10/2018		464EUR02 460 8EF 2018 AKRAPOVIC.mot	DOWNLOAD
12/10/2018		304EUR01 300 8EF 2018 AKRAPOVIC.mot	DOWNLOAD



CARBURATION

Modify the carburation setting:

- 125cc

carburator	delivered version	racing version
jet needle	N84K	N1EE
idle jet	KEP 38	KEP 42
main jet	KEA 115	KEA 170
cold start jet	50	85
idle air regulation screw	1 and 1/2 turn	1 and 1/2 turn

- 250cc

carburator	delivered version	racing version
jet needle	N84K	N1EG
idle jet	KEP 38	KEP 40
main jet	KEA 115	KEA 162
cold start jet	50	85
idle air regulation screw	1 and 1/2 turn	1 and 1/2 turn

- 300cc

carburator	delivered version	racing version
jet needle	N84K	N8RE
idle jet	KEP 38	KEP 40
main jet	KEA 115	KEA 165
cold start jet	50	85
idle air regulation screw	1 and 1/2 turn	1 and 1/2 turn

ELECTRICAL

First of all remove:

- Seat
- Fuel tank
- Side panels
- Front headlight



Remove the original light switch (0413) and install the racing switch (3507) in the same position on the left handle.



Remove original main standard lighting sub harness P/No.8145 and replace with the racing lighting sub harness.6845.



Start to disconnect:

- a) power plug
- b) rear brake light / tail light wiring connection
- c) speedo connection
- d) left handle bar lighting switch



Remove original accessory wiring sub harness (3509) and start disconnect:

- a) Turn indicator flasher unit wiring connector
- b) LHF and RHF Turn indicator wiring connectors
- c) Turn indicator bullet style wiring connectors
- d) Head light wiring connector
- e) On the rear of the bike, connect the plate light

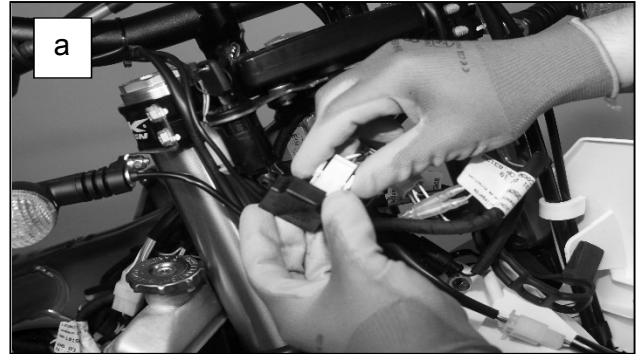
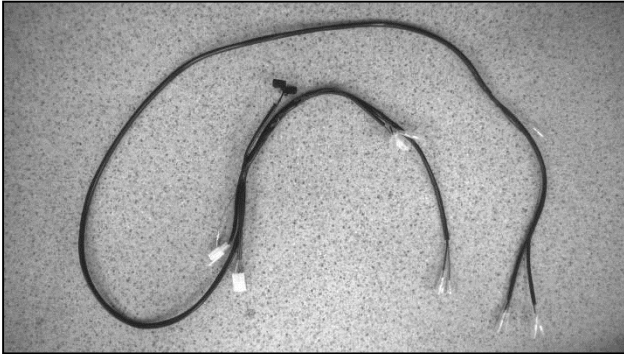

Remove original speedo holder (4389) and replace with racing speedo bracket 4526



Remove the 4 indicator



Remove horn and horn bracket

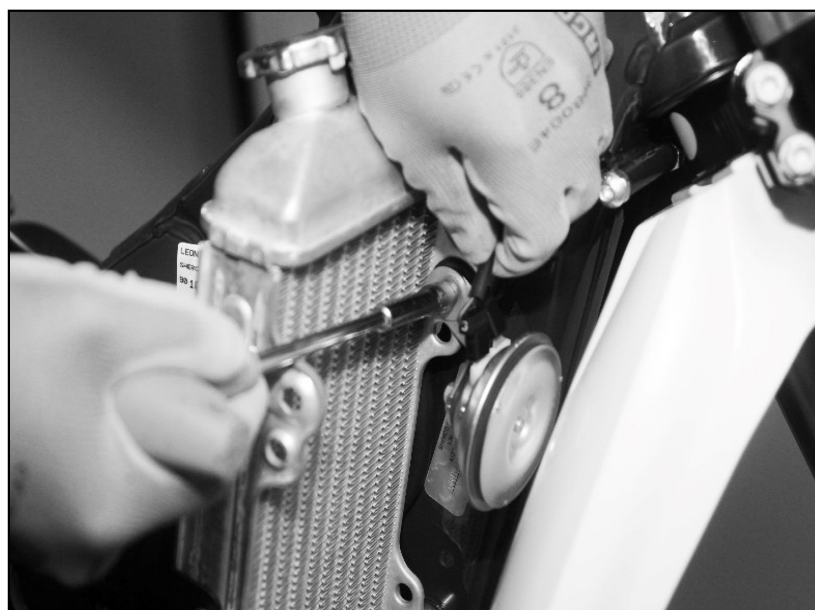

Remove the rear fender extension (3549)

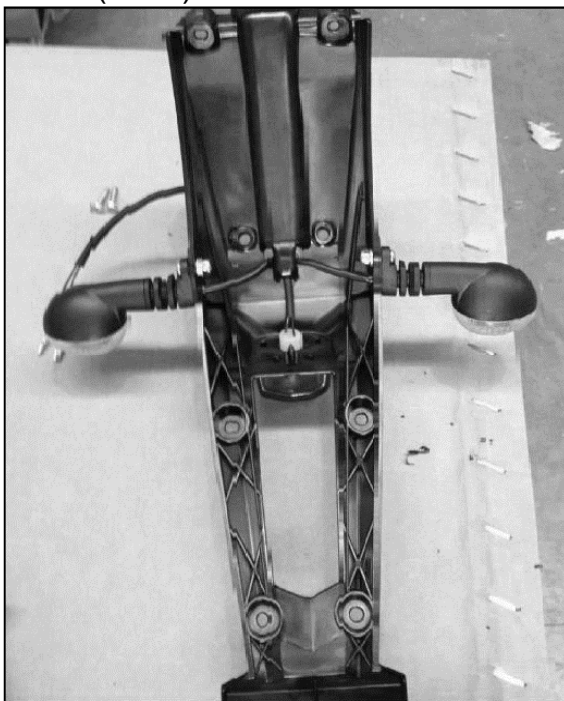

Remove left and right mirrors to the handle bar

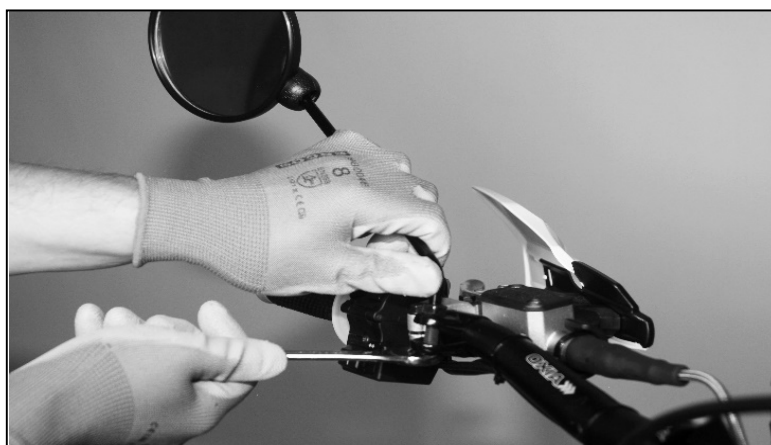

Do not connect the brown wire on the racing harness 6845



SHERCO

AN EMOTION IS BORN

